



TTSIM-2

TraceTek® Sensor Interface Module with LCD and Relay

Easy setup and simple operation

The TTSIM-2 Sensor Interface Module monitors up to 150 meters (500 feet) of TraceTek sensing cable. When liquid is detected, the TTSIM-2 unit indicates the leak, displays the location of the leak and switches a relay to provide local voltage-free contact closure. The TTSIM-2 can also communicate to a host monitoring system such as a TraceTek TTDM-128 or directly to a PLC or other host system using standard protocols. The low cost of the TTSIM-2 makes it economical to build very robust systems with many small independent sensing cable segments. No field calibration is required.

The TTSIM-2 can be used as a stand-alone leak detection alarm unit, or in networks with other TraceTek TTSIM, TT-NRM or TTDM-128 modules. The TTSIM-2 can be configured using a Microsoft Windows™ based PC, or a TraceTek TTDM-128 network master module.

Design Features

- Voltage-free contacts for alarm signaling.
- LED's to indicate power, leak, cable trouble, and communication status.
- Leak location display on LCD.
- Simple twisted pair serial RS-485 communications up to 1200 meters (4000 feet) with automatic protocol selection (MODBUS, Opto 22 and Metasys).
- Available for 24, 120 or 230 Vac 50/60 Hz power supply.
- Each TTSIM-2 unit has a unique address assigned with software – no switches.
- Relay software selectable for normally energized or normally de-energized operation.
- DIN rail mounted for easy installation.
- Selectable unit of measure (Feet or Meters).

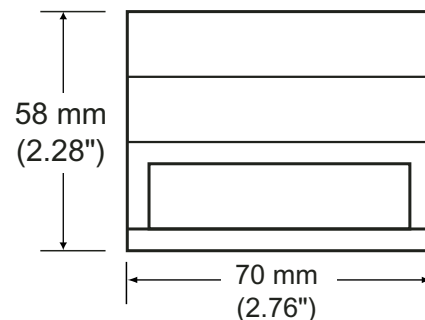
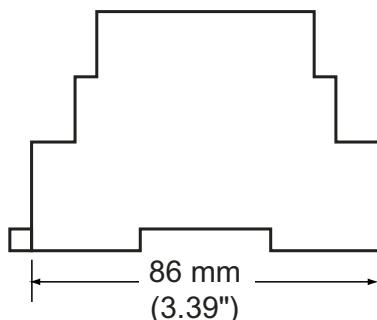

General features

Sensor compatibility	All TraceTek sensor cables and point sensors or contact closure devices
Maximum length of sensing cable	150 m (500 ft)
Precision	0.5% of sensor length ± 0.6 m (2 ft)

Environmental ratings

Storage temperature	-18°C to 60°C (0°F to 140°F)
Operating temperature	0°C to 50°C (32°F to 122°F)
Humidity	5% to 95% non-condensing

Power requirements

TTSIM-2	22 to 26 Vac, 50/60 Hz, 3 W
TTSIM-2-120	92 to 132 Vac, 50/60 Hz, 3 W
TTSIM-2-230	216 to 253 Vac, 50/60 Hz, 3 W

Ordering information

Catalog Number	Description
TTSIM-2	24 Vac TTSIM-2
TTSIM-2-120	120 Vac TTSIM-2
TTSIM-2-230	230 Vac TTSIM-2

TTSIM-2 Sensor Interface Module

Serial interface	Network configuration	RS-485 two wire network, 9600 baud, addressable from 1 to 127
	Communication protocol	MODBUS™, OptoMux™ or Johnson Controls Metasys™
Relay contacts	Type	Form C (SPDT)
	Action	Software selectable; normally energized or normally de-energized (default); alarm on leak or alarm on leak and sensor fault
	Rating	2 Amps maximum, 250 Vac or 30 Vdc

Approvals & Certifications

The TTSIM-2 unit is approved for use in ordinary areas. The module must be located in an ordinary area, but may monitor intrinsically safe TraceTek sensors located in hazardous locations, as shown below.

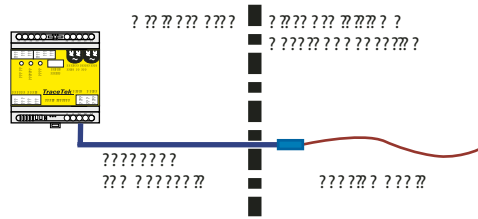

TraceTek sensors in Class I, Division 2, Groups A, B, C, D Hazardous Locations (Zone 2 in Europe).

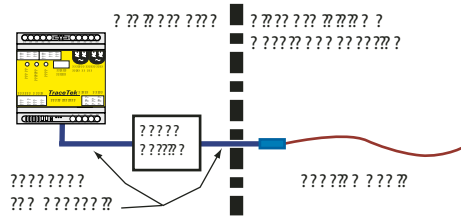

If protected by an agency approved zener barrier, TraceTek sensors in Class I, Division 1, Groups A, B, C, D Hazardous Locations (Zones 0 and 1 in Europe). Contact Tyco Thermal Controls to select proper zener barrier.

Tyco Thermal Controls
300 Constitution Drive
Menlo Park, CA 94025-1164

Distributed by:

Industrial Heater
8400 Wolf Lake Drive
Suite 116
Bartlett, TN 38133
Tel: (888)451-4328
Fax: (901)382-4766
E-mail: info@iheater.com
www.iheater.com

Important: All information, including illustrations, is believed to be reliable. Users, however, should independently evaluate the suitability of each product for their particular application. Tyco Thermal Controls makes no warranty as to the accuracy or completeness of the information, and disclaims any liability regarding its use. Tyco Thermal Controls' only obligations are those in the Tyco Thermal Controls Standard Terms and Conditions of Sale for this product, and in no case will Tyco Thermal Controls or its distributors be liable for any incidental, indirect, or consequential damages arising from the sale, resale, use or misuse of the product. Specifications are subject to change without notice. In addition, Tyco Thermal Controls reserves the right to make changes – without notification to Buyer – to processing or materials that do not affect compliance with any applicable specification.

Tyco, TraceTek and the TraceTek logo are trademarks of Tyco Thermal Controls LLC or its affiliates. MODBUS is a trademark of Gould, Inc. OptoMux is a trademark of Opto-22. Metasys is a trademark of Johnson Controls. Windows is a trademark of Microsoft Corporation.